

LOC		DIST		REVISIONS			
GP	00	REV	DATE	DESCRIPTION	DATE	BY	APPV
F		1	09APR93	REVISED PER ECO-08-007327		BM	WM

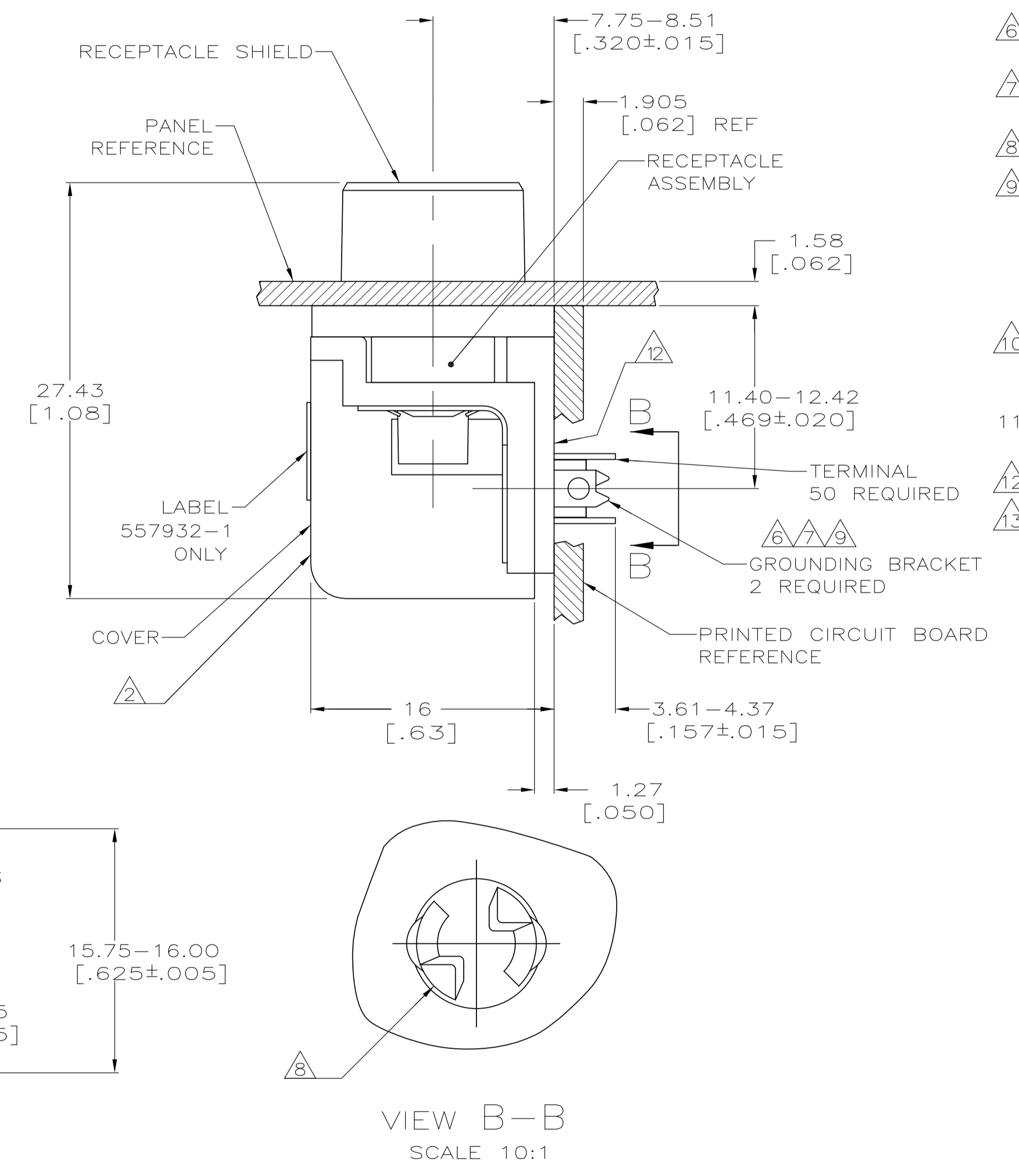
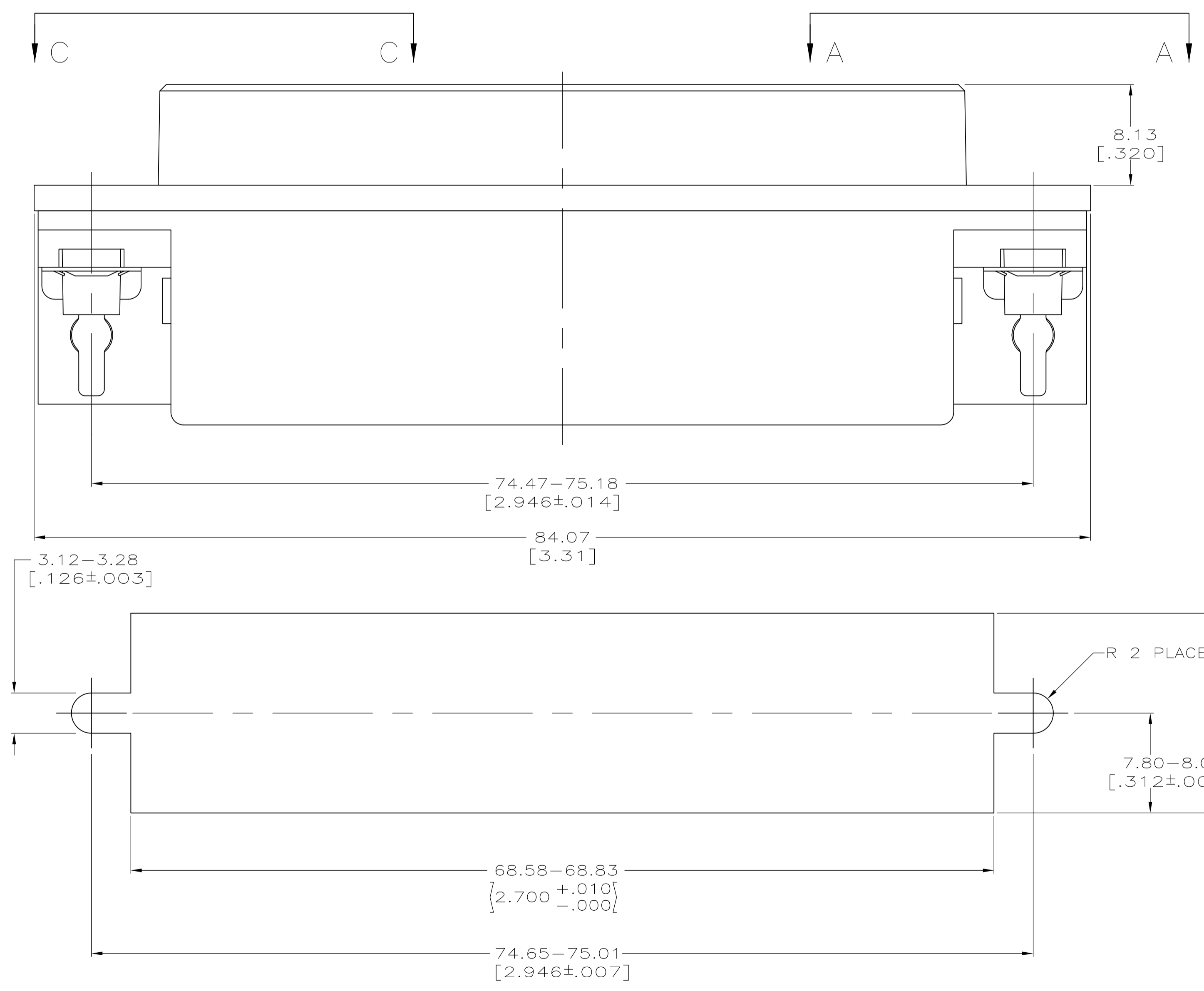
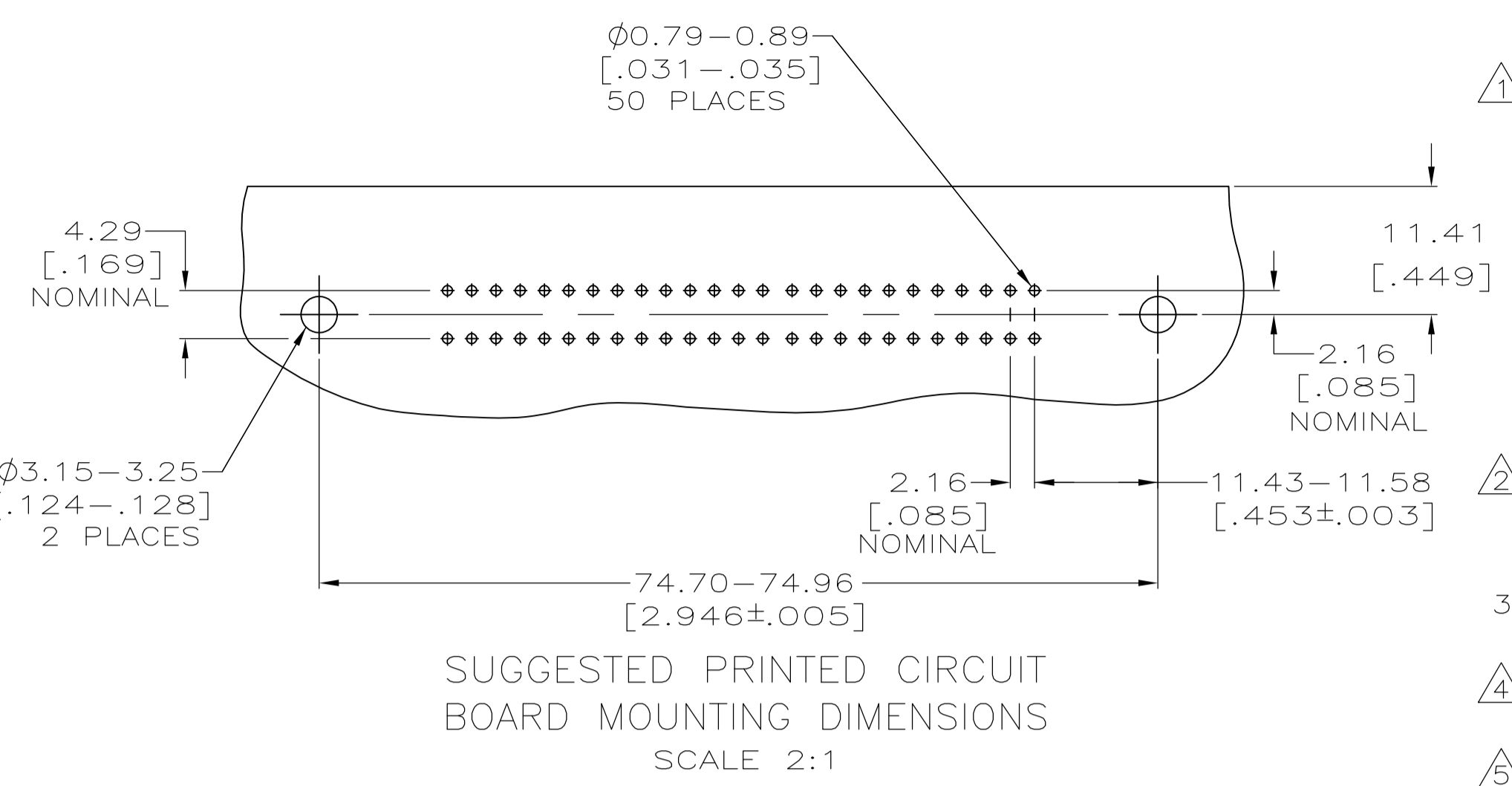
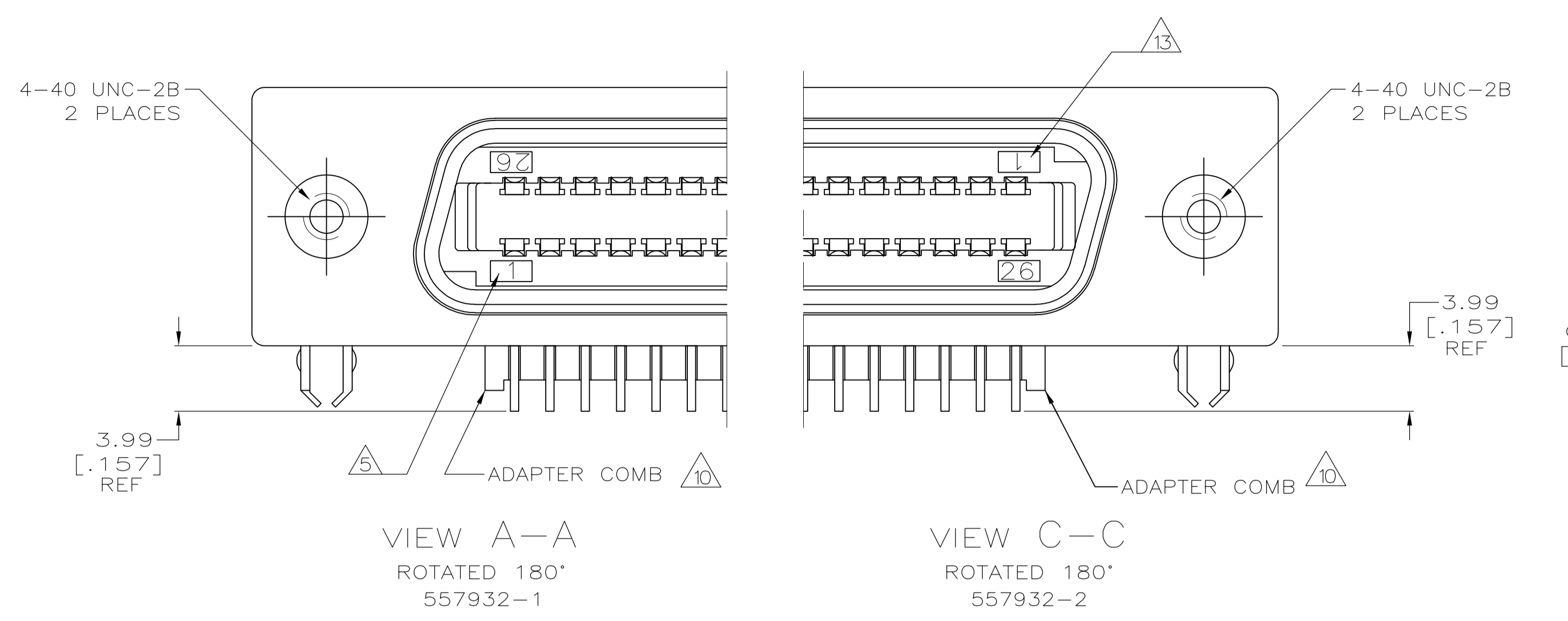

- 1 MATERIAL:  
SUPPORT PLATE - POLYESTER, NATURAL (OR EQUIVALENT).  
HOUSING & ADAPTER COMB - POLYESTER, BLACK.  
RECEPTACLE SHIELD - BRIGHT NICKEL OVER COPPER PLATED ZINC.  
TERMINALS - HIGH STRENGTH COPPER ALLOY PLATED WITH EITHER 0.76μm [.000030] MIN GOLD PLATE OR GOLD FLASH OVER PALLADIUM NICKEL PLATE, 0.76μm [.000030] MIN TOTAL ON MATING SURFACE. 3.05μm [.000120] MIN TIN-LEAD PLATE ON TAILS. ALL OVER 1.27μm [.000050] MIN NICKEL UNDERPLATE OVER ENTIRE TERMINAL.  
GROUND BRACKET - TIN-LEAD PLATED CARBON STEEL.
- 2 COVER - POLYESTER, NATURAL, (OR EQUIVALENT), PLATED MATTE COPPER 3.81μm [.000150] MINIMUM THICK, BENEATH MATTE NICKEL PLATE, 3.81μm [.000150] MINIMUM THICK.
- 3. CENTER TO CENTER SPACING OF TERMINALS IS 2.16 [.085] NOMINAL.
- 4 ALL DIMENSIONS SHOWN ARE MAXIMUM UNLESS OTHERWISE SPECIFIED.
- 5 TERMINAL 1 LOCATED IN THIS ROW FOR REVERSE ORIENTATION. SEE VIEW A-A.
- 6 GROUNDING BRACKET RETAINS CONNECTOR IN 1.57 [.062] THICK PC BOARD WITHOUT ADDITIONAL HARDWARE.
- 7 GROUNDING BRACKET LOCATES CONNECTOR FLUSH WITH TOP OF PC BOARD AND SPRING LOCKS BENEATH.
- 8 CYLINDRICAL SHAPE OFFERS 180° OF SOLDERING SURFACE.
- 9 SURFACE AREA OF GROUNDING BRACKET BELOW PC BOARD SHALL PASS SOLDERABILITY REQUIREMENTS IN ACCORDANCE WITH TYCO SPECIFICATION 109-11-2. DISCOLORATION, SCRATCHES, SPOTS AND OTHER COSMETIC DEFICIENCIES TYPICAL OF BARREL PLATING PROCESSES ARE ACCEPTABLE PROVIDING PARTS PASS 24 HOUR EXPOSURE AT 95% RH AT 40°C WITHOUT EVIDENCE OF CORROSION.
- 10 IF TERMINALS DO NOT EXTEND BELOW COMB, SHALL BE PARTIALLY RETRACTED BEFORE INSERTING CONNECTOR INTO PC BOARD.
- 11. THE CONTACT SURFACES OF THE TERMINALS ARE COATED WITH LUBRICANT.
- 12 SUPPORT PLATE (UNPLATED).
- 13 TERMINAL 1 LOCATED IN THIS ROW FOR STANDARD ORIENTATION. SEE VIEW C-C.

DESCRIPTION	PART NUMBER
STANDARD ORIENTATION, VIEW C-C	557932-2
REVERSE ORIENTATION, VIEW A-A	557932-1

THIS DRAWING IS A CONTROLLED DOCUMENT.		DIN JOEL H. WOOTEN 05-APR-93		Tyco Electronics Corporation Harrisburg, PA 17105-3608	
DIMENSIONS: mm [INCHES]		TOLERANCES UNLESS OTHERWISE SPECIFIED:		APPROVED R. FLAHERTY 08-APR-93	
0 PLC	± .005	1 PLC	± .005	NAME RECEPTACLE ASSEMBLY, SHIELDED, RIGHT ANGLE, 50 POSITION, BOARD LOCK, PLATED COVER, AND SCREW LOCK, CHAMP®	
1 PLC	± .005	2 PLC	± .005	APPLICATION SPEC	
2 PLC	± .005	3 PLC	± .005	SIZE A1	
3 PLC	± .005	4 PLC	± .005	CAGE CODE 00779	
4 PLC	± .005	ANGLES	± .005	DRAWING NO 557932	
MATERIAL	FINISH	WEIGHT	SCALE	SHEET 1 OF 1	
1	1		4:1	REV F	